



TD450



harman/kardon

English - CD Transcription Quality Cassette Deck OWNER'S MANUAL

Français - Platine-cassette qualité enregistrement de disques compacts NOTICE D'EMPLOI

Deutsch - Kassettendeck für Überspielungen in CD-Qualität EIGENTÜMERHANDBUCH

Italiano - Piastra ad alta fedeltà di registrazione da lettori di compact disc MANUALE OPERATIVO

Español - Grabadora de calidad de transcripción de discos compactos MANUAL DEL PROPIETARIO

Nederlands - Casettedeck met CD-transcriptie kwaliteit HANDLEIDING

Svenska - Kassettdäck med CD-återgivningskvalitet BRUKSANVISNING

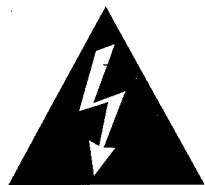

CAUTION
RISK OF ELECTRIC SHOCK
DO NOT OPEN



CAUTION: TO REDUCE THE RISK OF ELECTRIC SHOCK, DO NOT REMOVE COVER (OR BACK). NO USER-SERVICEABLE PARTS INSIDE. REFER SERVICING TO QUALIFIED SERVICE PERSONNEL.



The lightning flash with arrowhead symbol, within an equilateral triangle, is intended to alert the user to the presence of uninsulated "dangerous voltage" within the product's enclosure that may be of sufficient magnitude to constitute a risk of electric shock to persons.



The exclamation point within an equilateral triangle is intended to alert the user to the presence of important operating and maintenance (servicing) instructions in the literature accompanying the appliance.

WARNING: TO REDUCE THE RISK OF FIRE OR ELECTRIC SHOCK, DO NOT EXPOSE THIS APPLIANCE TO RAIN OR MOISTURE.

Harman Kardon TD450

Date of purchase _____

Purchased from _____

Address of business purchased from _____

Installed by _____

Date of installation _____

Serial No. _____

Handle the Power Cord Gently

- To disconnect the plug from the AC outlet, pull on the plug itself, not on the cord. Pulling the cord may break the wire.
- Disconnect the plug from the AC outlet whenever the unit is to be left unused for an extended period of time.

- Do not place furniture or other heavy objects on the cord, and avoid dropping heavy objects on it. Also do not make a knot in the cord; this can damage it and cause a fire hazard.

General Instructions

Place of Installation

Place the cassette deck on a firm and level surface. Avoid installing it:

- In moist or humid places;
- Close to heating equipment or in places exposed to direct sunlight;
- In a direct draft from an air conditioner or in other very cold locations;
- In places subject to excessive vibration or dust;
- In poorly ventilated places;

Moving the Unit

Before moving the unit, be sure to unplug the power cord and disconnect all wires to other stereo components.

Do Not Open the Cabinet

Except for performing routine maintenance (see page 10), do not attempt to service this unit. Tampering with internal components can cause fire or shock, and may void your guarantee.

If water or small objects enter the unit, unplug the power cord immediately and consult an authorized Harman Kardon service center. Using the unit under such conditions may cause a fire or shock hazard.

Cleaning

Remove dust by wiping the unit with a soft, dry cloth. If necessary, use a soft cloth lightly dampened with mild soapy water; then wipe with a dry cloth. Never use benzine, thinner, alcohol or other volatile agents, and avoid spraying insecticides near the unit.

TABLE OF CONTENTS

| | |
|-----------------------------------|----|
| General Instructions | 2 |
| Features | 3 |
| Panel Controls and Displays | 4 |
| Remote Control | 6 |
| Operating Instructions | 7 |
| Installation | 9 |
| Troubleshooting | 11 |
| Specifications | 12 |

TD450 Features

Thank you for choosing a Harman Kardon cassette deck.

And congratulations. Your new unit is an exceptionally well-engineered product that will give you years of superb performance.

The special features of this cassette deck include:

- **CD Transcription Quality**
The TD450 has been engineered for wide, flat frequency response, low noise, and low distortion, so as to produce high fidelity recordings from compact discs and other high-quality sound sources.
- **Discrete Circuitry**
For maximum design flexibility and highest possible performance, Harman Kardon designs a playback circuitry using discrete electronic components, not off-the-shelf integrated circuits.
- **Large Fluorescent Display**
Function settings and signal levels are indicated in bright, clear alphanumeric and easy-to-read format.

- **Advanced Ergonomic Design**
Controls are engineered and positioned for simple, error-free recording and playback.
- **Music Search**
Skip Forward and Reverse buttons rapidly locate the start of any desired segment on a pre-recorded tape.
- **3 Heads**
The 3-head design allows the user to play back a tape as it is being recorded and make instantaneous comparisons between the source and the recording. The user can then make adjustments to the record level, balance or bias while the recording is in progress.
- **Automatic Tape Source Selector**
The "Tape Source" button is automatically set to monitor the tape when the unit is in play mode, and to monitor the input signal when the unit is in the recording mode. The user can override the automatic setting by pressing the "Tape Source" button.

- **Wireless Remote Control**
This unit has a front panel IR remote sensor and an accessory remote control. It is also compatible with the cassette deck commands included on system remote controls included with all Harman Kardon remote controlled receivers, integrated amplifiers and pre-amplifier/tuners.
- **Dolby HX Pro**
Special recording circuitry automatically monitors signal levels and adjusts bias in the presence of momentary high frequency peaks. This allows you to record at higher input levels (for better signal quality) without distortion. Dolby HX Pro operates automatically whenever recordings are made, and the resulting higher-fidelity tape can be played back on any cassette deck.

To get the most from your new cassette deck, please read this manual carefully and follow its instructions. Save the manual for future reference. Dolby noise reduction and HX Pro headroom extension manufactured under license from Dolby Laboratories Licensing Corporation. HX Pro originated by Bang & Olufsen.

"Dolby", the double-D symbol  and "HX Pro" are trademarks of Dolby Laboratories Licensing Corporation.



Harman Kardon TD450

Cassette Deck Controls and Displays

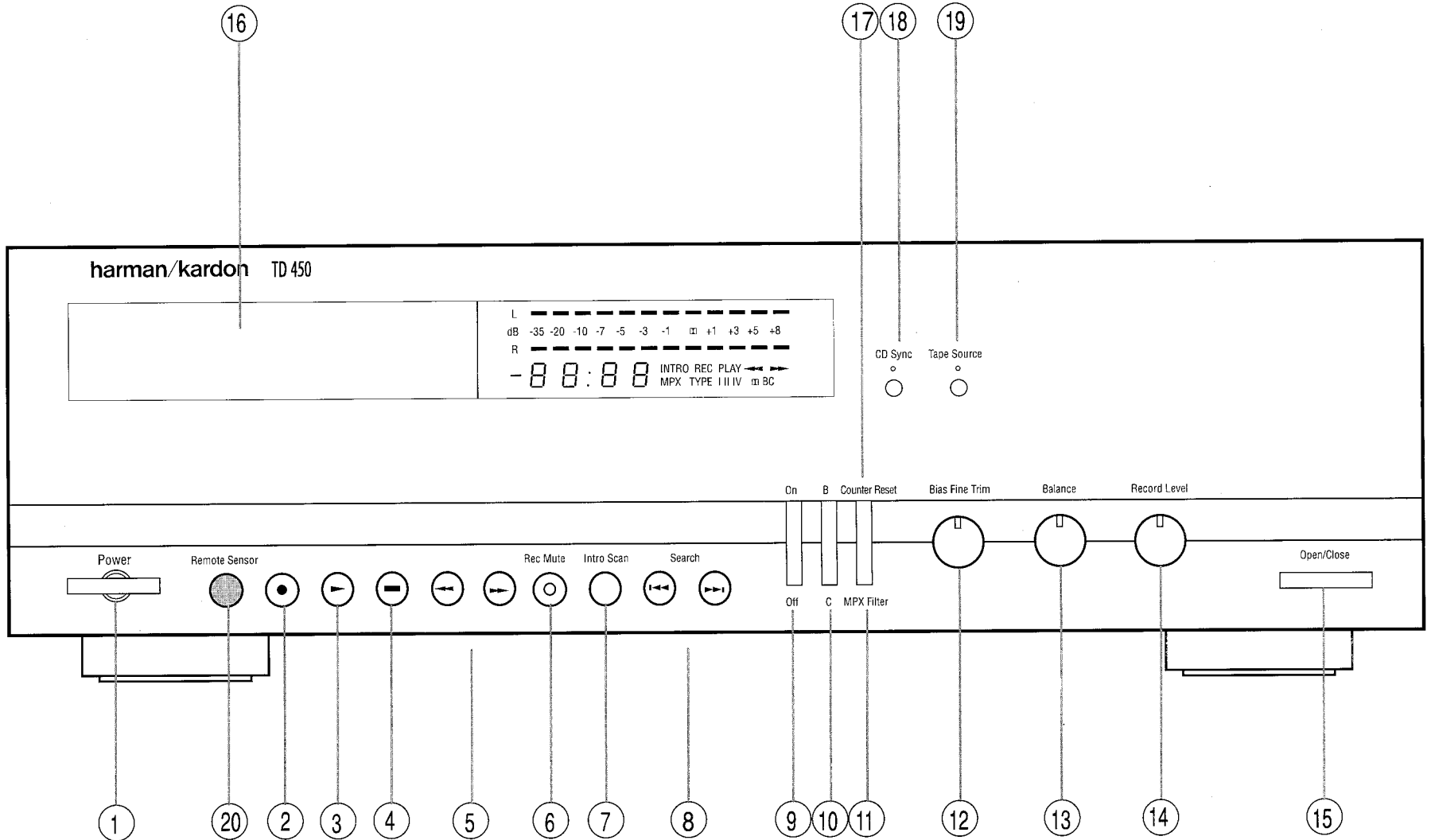

Controls and Displays

1. Power Switch

Press to turn unit on/off.

2. Record/Pause

Puts cassette deck in Record ready or pause mode.

3. Play

Begins playback or recording.

4. Stop

Stops tape transport in any mode.

5. Rewind/Fast Forward

Rapidly rewinds/advances tape.

6. Record Mute

Inserts blank space when recording.

7. Intro Scan

Previews each segment on a pre-recorded tape.

8. Search Forward and Reverse

Locates the start of any desired segment on a pre-recorded tape. (See page #5)

9. Dolby NR

Activates Dolby Noise Reduction circuitry for playing or recording tapes.

10. B/C

Selects Dolby B or Dolby C Noise Reduction.

11. MPX Filter

Press when recording FM stereo broadcasts using Dolby noise reduction.

12. Bias Fine Trim

Adjust when recording. (See page #6)

13. Balance

Adjusts balance between left and right channels when recording.

14. Record Level

Adjusts recording level.

15. Open/Close

Press to load/remove tape cassette.

16. Cassette Compartment/Drawer

17. Counter Reset

Resets Tape Counter to 00:00.

18. CD Sync

Engage when synchronizing recording with a Harman Kardon CD Player.

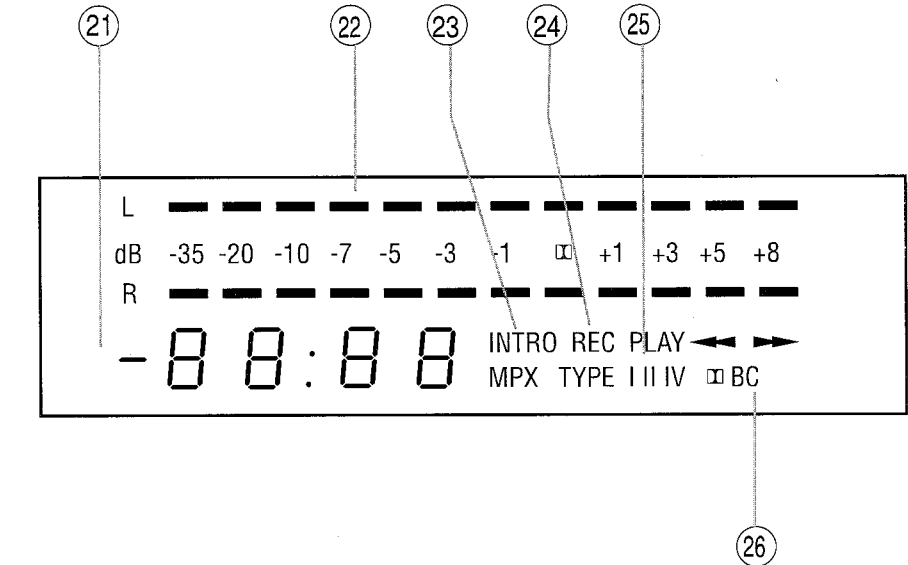

19. Tape Source

Selects between the signal recorded on the tape and the input source signal. When "Tape" is selected the indicator above the button will light.

20. Remote IR Sensor

Receives the remote control signals.

21. Counter

Indicates tape position in minutes and seconds.

22. Level

Shows signal level.

23. Intro

Indicates Intro Scan is engaged.

24. REC, PLAY,

Displays operating mode: Record, Play, Rewind or Fast Forward.

25. TYPE I II IV

Automatically indicates type of tape in use.

26. Dolby B C

Shows if Dolby B or C circuits are on.



Remote Control

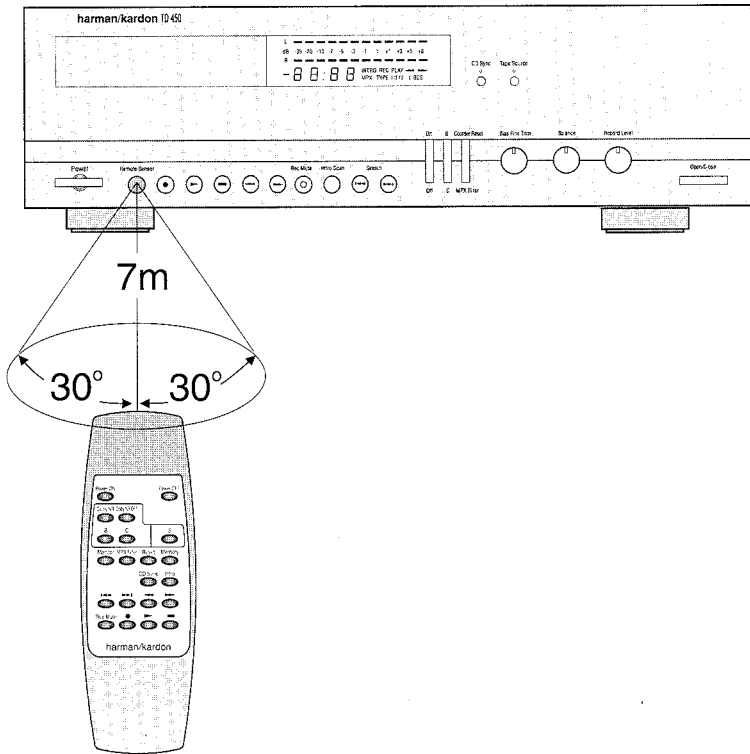

Remote Control

The keys on the remote control function in the same way as the keys on the front panel of the cassette deck. (please see the previous page for the function of each key.) This remote control operates within a distance of 7 meters while directly in front of the unit and at an angle of up to 30 degrees. Strong fluorescent lighting or sunlight in the room may shorten this range, as will dust or dirt which may accumulate on the remote control lens or the front panel remote sensor. Also, avoid blocking the line of sight between the cassette deck and the remote control. The remote control is powered by two AA batteries, included in the carton. When the batteries weaken, replace both of them at the same time. If the remote control will be unused for a long period of time, remove the batteries to prevent damage from corrosion.

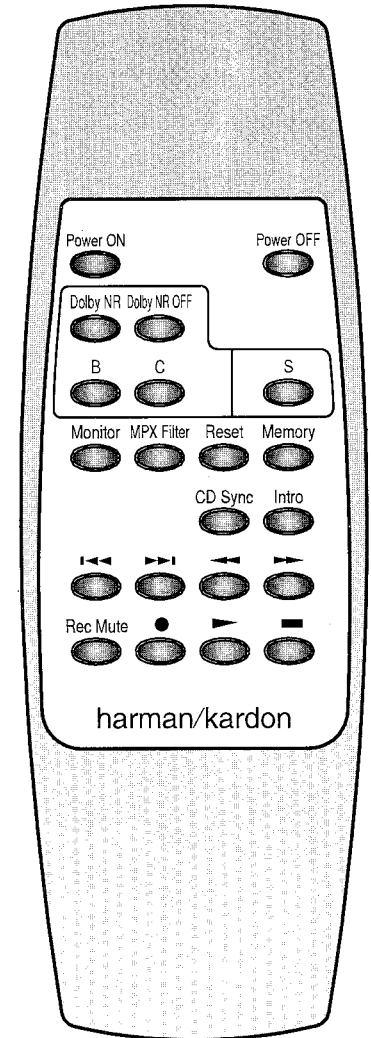



Operating Instructions

Inserting a Tape

1. Check cassette tape for excessive slack. If necessary, insert a pencil into one of the cassette hubs and rotate to take up the slack.
2. Press Open/Close.
3. Insert cassette, tape side toward rear of unit, and close compartment door.



Playing a Tape

1. If tape was recorded with Dolby Noise Reduction, press Dolby NR button.  and "B" or "C" will appear on the display panel. Choose B or C by pressing the B/C button.
2. Press  to begin play.



Previewing a Tape

1. Press Intro Scan. Cassette deck locates the beginning of recorded

material and plays for 15 seconds. Tape is then advanced to the beginning of each successive recorded segment, or track, playing for 15 seconds before automatically advancing to the next track.

2. To stop Intro Scan, press . Or, press  during any 15-second play segment, and tape will continue to play.

Locating Places on a Tape

1. To move quickly to the beginning of any desired selection, use the Search Reverse and Search Forward buttons ( and  at lower left corner of the deck).

To skip to the beginning of the previous track, press  again quickly before the present track begins playing.

2. Use the Counter. The Linear Time Counter indicates approximate tape position in minutes and seconds. Press Counter Reset at the start of a cassette to identify any desired point on the tape. (Elapsed time is maintained in Fast Forward and Rewind.) When counter is reset to 00:00 at the beginning of a cassette, the approximate time remaining can be determined by subtracting the counter reading from the total tape time. The Linear Timer Counter accuracy is

typically within 1 minute of the tape's actual running time.

Recording a Tape

1. Bias Fine Trim knob to middle position or to previously determined proper position for the tape (refer to following section for details).

2. Press the Dolby NR button to turn Dolby circuitry on/off, and press B/C button to select Dolby B or C as follows:

- a. To record a tape without Dolby Noise Reduction, turn the Dolby NR switch off.

- b. To record a tape with Dolby Noise Reduction, turn the Dolby switch on, and select Dolby B or C with the B/C switch.

- c. When recording with Dolby Noise Reduction, consider the equipment on which you will play your tape. If playback equipment is not equipped for Dolby, turn the Dolby switch Off. If it is equipped for Dolby, turn the Dolby switch On; then select B if playback device is equipped only for Dolby B; otherwise select C.

3. If you are recording an FM stereo broadcast using Dolby B or C, turn on MPX Filter. Otherwise turn the MPX Filter Off.

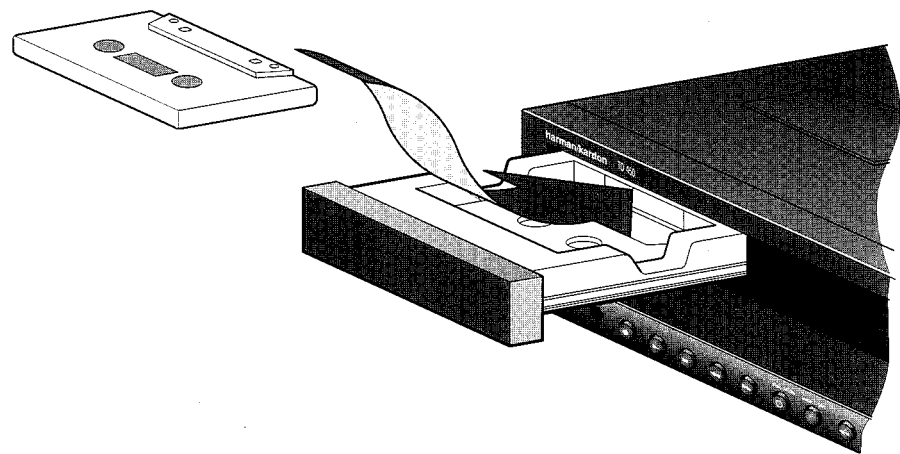

4. Press ●. ("REC" will flash on and off on display panel.)

5. Play one of the louder segments of the material to be recorded.

6. Check the signal levels indicated by the bars marked L and R on the display. If levels are constantly unequal, turn the Balance knob left or right to correct the imbalance.

7. Check the Display Panel to determine the tape Type (I, II or IV), and set Input Level accordingly:

a. For Types I and II, the loudest material should illuminate the colored bars at +1 or +3dB;

b. For type IV, the loudest material should illuminate the bars at +3 or +5dB.

8. Return to the beginning of the material to be recorded.

9. Press ► to begin recording. (REC will be continuously displayed.)

10. At end of material to be recorded:

a. Press ■ (Stop); or

b. Press Rec Mute. This records 4 seconds of silence on the tape and

returns the deck to Record. Press ► to continue recording.

11. Press the "Tape Source" button if you would like to hear the actual signal recorded on the tape. The indicator lights when it is set for the signal on the tape.

Setting Bias Fine Trim

Bias Fine trim enables you to get optimal wideband recordings by adjusting the bias setting for the specific tape you are using.

Use the following procedure to find the best bias fine trim setting:

1. Insert blank tape.

2. Turn off Dolby NR.

3. Begin recording.

4. Adjust the Input level as per previous instructions.

5. Press the "Tape source" button so that you can hear the actual signal recorded on the tape.

6. Adjust the Bias Fine Trim knob so that the recording sounds as close to the original as possible.

7. Press the "Tape Source" button as often as necessary in order to compare the recording to the original.

Recording Using the CD Sync Feature

To use the CD Sync feature first be sure that the TD450 is correctly connected through its rear panel Remote Out jacks to the Remote In jacks on a Harman Kardon CD player (refer to page 9).

Once connected, the cassette deck will control the PLAY, PAUSE, and STOP functions of your Harman Kardon CD player. To activate the CD Sync function, press the CD Sync button on the front panel of the TD 450. The green LED will illuminate.

NOTE: Anytime the STOP button on the cassette deck is pressed the CD Sync function will turn off automatically.

To Record an Entire Disc

First make sure that you have selected the CD input on your Pre-Amp, Amplifier or Receiver. Set record and bias levels (refer to Recording a Tape Pg. 7). Put the CD Player in the STOP mode. To begin recording push the CD Sync button. The cassette deck will begin recording as the CD player begins to play the disc.

To Record a Selected CD Track or a Pre-programmed Sequence of Tracks

Preset the track to be recorded or program the CD player as you normally would, and press the CD Sync button on the cassette deck.

NOTE: Pressing the PLAY, STOP, or PAUSE buttons on the CD player will have no effect on the operation of the cassette deck.

Rec/Pause:

When in the CD Sync Mode, when REC/PAUSE button on the cassette deck is pressed, the CD player will automatically pause. When the PLAY button on the cassette deck is subsequently pressed, the CD player will resume playing as the cassette deck resumes recording.

Stop:

When you are finished recording press the STOP ■ button on the cassette deck. The CD player will also stop. Pressing the STOP button will also de-activate the CD Sync mode.

Installation

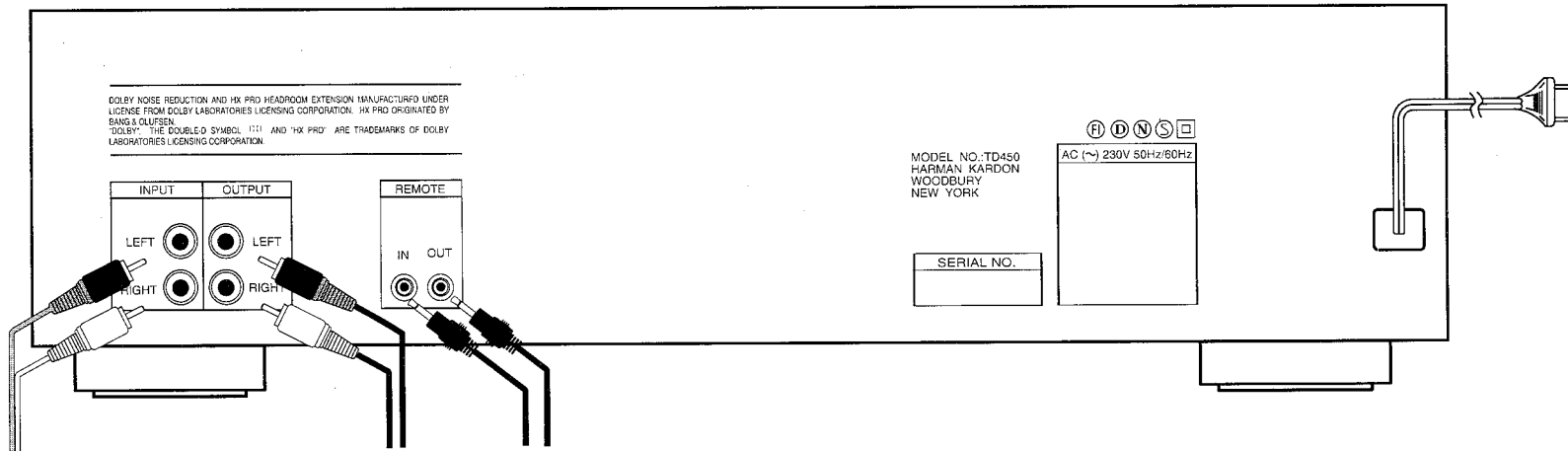

Packaging

Save all packing material. It is essential for shipping should you move or in the event the unit ever needs repair.

Placement

Unit may be placed on top of or beneath other stereo components, so long as its placement meets the cooling requirements of the component beneath it.

Hook-up

1. Make sure all stereo components are turned off.
2. Use the cable provided to connect the left and right input jacks of the cassette deck to the "Tape Output" jacks of your pre-amplifier, integrated amplifier or receiver.
3. Connect the left and right Output jacks on the deck to the "Tape Input" jacks (often labeled "Play") on your receiver/pre-amp/integrated amplifier.

NOTE: If you are using an equalizer and/or other external signal processing components, which are now connected to the Tape Monitor loop of your receiver/pre-amp/integrated amplifier, you have two choices:

- a. Connect the deck to the Tape Monitor loop provided on the last outboard component; or
- b. If your receiver/pre-amp/integrated amplifier has two Tape Monitor loops, you may connect the cassette deck to the unused loop. (In this case, the cassette deck will be unaffected by the external signal processing components.)

AC Power

Plug the cord into a polarized wall socket, polarized extension cord, or AC convenience outlet on another stereo component.

CD Sync Connection

Connect the TD450 "Remote Out" jack to the "Remote In" jack on a Harman Kardon CD Player.



Wired Remote Control

If you wish to control your deck with an external infrared remote control sensor, connect the wire from the remote sensor to your cassette deck's "Remote Input" jack. (A control wire may then be run from the deck's "Remote Output" jack to the "Remote Input" of another stereo component.)

Alternatively, if you have a stereo component with a built-in infrared remote sensor and a "Remote Output" jack, it may be possible to connect this jack to the "Remote Input" jack of your cassette deck. Not all components are compatible, but it will not hurt to experiment.

In addition, most Harman Kardon Receivers include a System Remote Control which will control the functions of the cassette deck.

Cleaning the Tape Heads

Tape heads must be cleaned periodically to remove tape particles, which gradually build up on the heads, impairing sound quality and increasing wear on tapes. Heads may be cleaned in either of two ways:

1. Slightly dampen a cotton swab in isopropyl alcohol and gently rub the surfaces of each tape head. Use a second dampened swab to clean other surfaces coated with tape material. Repeat this cleaning every 30 tapes. The TD450 is equipped with an access hole on the top of the unit to facilitate cleaning of the heads. Be careful not to lose the cover to this access hole.

2. Use a tape head cleaning kit, which comes in the form of a tape cassette, and is simply inserted into the deck. Follow the instructions included with the kit.

Demagnetization

Tape heads and other internal parts gradually pick up magnetic fields, which can add noise to your tapes and even partially erase them. To prevent this problem, tape heads should be periodically demagnetized.

A battery-powered demagnetizer is easiest to use. It comes in the form of a tape cassette and is simply inserted into the deck. Be certain to use this demagnetizer as frequently as its instructions recommend.

Care of Tape

1. Store cassettes in their cases, in a location away from direct sunlight, excessive heat and high humidity.
2. Avoid placing a tape near a television set or loudspeaker; their magnetic fields can partially erase the tape.
3. To prevent accidental erasure of a tape, use a small screwdriver to remove the two square tabs located on the side of the cassette opposite the exposed tape. With these tabs removed, the tape cannot be recorded. If you later wish to record an erasure-protected tape, simply cover the small holes with adhesive tape.
4. Do not use old cassettes whose tape no longer moves smoothly from reel to reel. They may jam and damage your deck.

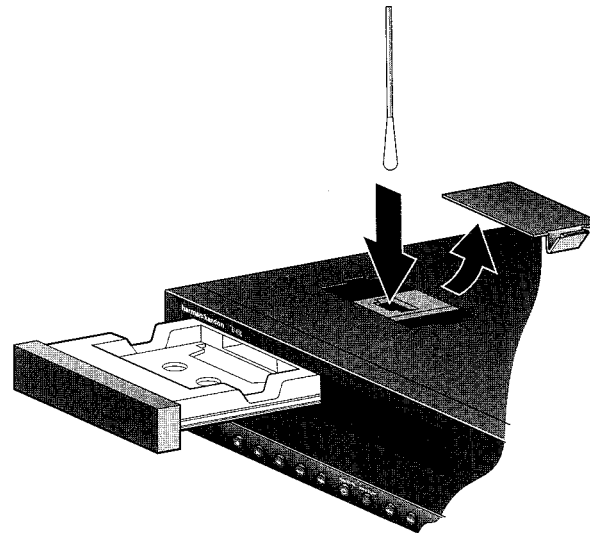

Troubleshooting

This unit is designed for trouble-free operation; most problems users encounter are due to operating errors. So if you have a problem, first check the chart below for a possible solution. If the problem persists, consult your authorized Harman Kardon service center.

If the Problem Is:

The Display Panel does not illuminate when the Power switch is pressed.

No sound is heard when Play is pressed.

The cassette deck does not record.

When a tape you have recorded is played back, the sound is distorted.

When a tape you have recorded is played back, the sound is muffled, with reduced high frequencies.

The CD Sync feature does not activate the CD player.

Make Sure That:

The power cord is plugged in securely.

The outlet is live.

The tape is not at its end.

The tape is not blank.

(Level indicators on the Display panel will flash if sound is recorded on the tape.)

The receiver/pre-amp/integrated amplifier is on, and its Source, Tape Monitor, and Speaker switches are set correctly.

The tape deck is connected properly.

The hookup wires are unbroken.

The Tape Source switch is set to Tape (indicator is on).

The erase-prevention tabs have not been removed from the tape cassette.

The Input Level knob is set high enough.

The tape deck is connected properly.

The hook-up cables are unbroken.

The Input Level was not set too high during recording.

The tape is not worn out.

The Dolby Noise Reduction switches were set correctly during recording.

The Dolby Noise Reduction switches were set correctly during recording.

The tape head is not dirty or magnetized (see Page #10).

A Harman Kardon CD player is being used.

The remote cable is connected between the TD450 and the CD player.



Specifications

| | TD450 |
|---------------------------------------|--|
| Tape Speed (cm/s): | 4,75 |
| Heads: | 3 |
| Record/Play Head Type: | Isotropic |
| Frequency Response, -20dB (IHF std): | 20Hz-20kHz +/-3dB w/metal tape |
| Typical Large Signal Response (0dB): | 20Hz-18kHz +/-3dB w/Dolby C & metal tape |
| Wow-and-Flutter: | |
| NAB, WRMS: | 0.05% |
| DIN: | 0.08% |
| Signal-to-Noise Ratio (Type II Tape): | |
| Dolby off: | 57dB |
| Dolby B on: | 65dB |
| Dolby C on: | 73dB |
| Total Harmonic Distortion | |
| 1kHz, metal tape, Dolby level: | 0,9% |
| Channel Separation: | 55dB |
| Channel Crosstalk: | 65dB |
| Erase Ratio: | 60dB |
| Bias Frequency: | 105kHz |
| Fast Forward and Rewind Time: | 90 sec (C-60) |
| Peak Reading Meter Range: | -35dB to +8dB |
| Output Level, 0dB, 10k Ohm load: | 640mV |
| Input Sensitivity (0dB) Line: | 45mV |
| Input Impedance Line: | 22k Ohms |
| Dimensions (w x h x d): | 442mm x 126mm x 320mm |
| Weight: | 5.4 kg |

DECLARATION OF CONFORMITY



We, Harman Marketing Europe a/s

Kongevejen 194B
DK-3460 Birkerød
DENMARK

declare that the product described in
this owner's manual is in compliance
with technical standards:

EN 55013/6 1990, EN 55020/6.1988,
EN 55022/4.1987

Accredited test laboratory:

MIKES PRODUCT SERVICE GmbH

Ohmstrasse 2-4

D-94342 Strasskirchen

Germany

Birkerød, DENMARK, 11. 17. 1994

A handwritten signature in black ink, appearing to read 'Steen Michaelсен'.

Steen Michaelсен

harman marketing europe a/s

*The appliance conforms with EEC directive
87/308/EEC regarding interference suppression*